

Left and Right speakers.

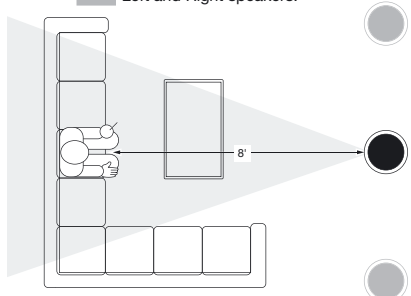

Figure 1. Typical placement for a surround system.

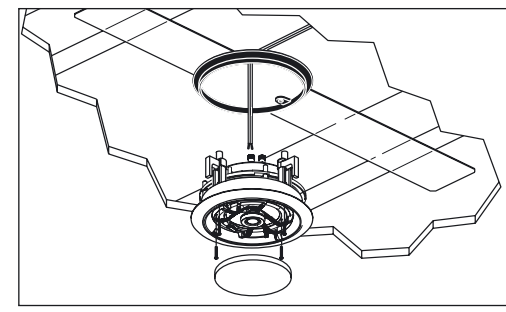

Figure 2. New construction bracket.

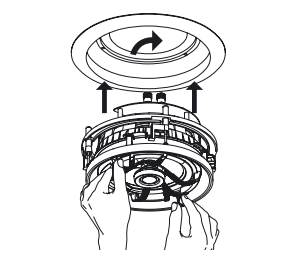

Figure 3. Installing the loudspeaker.

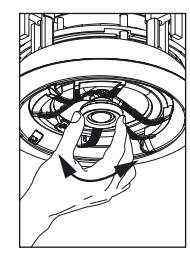

Figure 4. Tweeter adjustment.

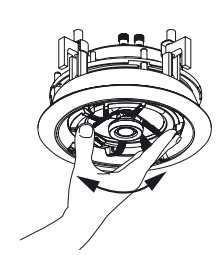

Figure 5. Woofer adjustment.



Figure 6. Treble level control.



Figure 7. Dialog level control.

**SPECIFICATIONS**

Model	Recommended Amplifier Power	Normal Impedance	Frequency Response	Sensitivity	Frame Dimensions	Hole Cut-Out Dimensions	Depth Behind Ceiling
<b>CM760DSC</b> Twist and Lock™ mechanism with Directed Soundfield™ patented fully pivoting assembly featuring one 7" Interlaced glass fiber woofer with butyl rubber surround and one pivoting 1" Teteron® tweeter with fluid cooling.	10 to 150 watts per channel	8 ohm nominal; 6 ohm minimum	48Hz - 21kHz +/-3dB	90 dB with 2.83 V pink noise input measured at 1 meter on axis	11 inches	9-3/4 inches	5-7/8 inches

**TECHNICAL SUPPORT**

IF YOU HAVE QUESTIONS ABOUT THE INSTALLATION OR OPERATION OF THIS OR ANY OTHER NILES PRODUCT, PLEASE CALL OUR TECHNICAL SUPPORT DEPARTMENT AT 1-800-BUY-HIFI (1-800-289-4434). SUPPORT IS AVAILABLE WEEKDAYS 8:00 A.M. TO 7:00 P.M. EASTERN TIME WITH THE EXCEPTION OF HOLIDAYS.

**LIMITED WARRANTY**

NILES AUDIO CORPORATION ("NILES") WARRANTS ITS LOUDSPEAKER PRODUCTS TO THE ORIGINAL PURCHASER TO BE FREE OF MANUFACTURING DEFECTS IN MATERIAL AND WORKMANSHIP FOR A PERIOD OF FIVE YEARS FROM DATE OF PURCHASE.

THIS WARRANTY IS SUBJECT TO THE FOLLOWING ADDITIONAL CONDITIONS AND LIMITATIONS. THE WARRANTY IS VOID AND INAPPLICABLE IF NILES DEEMS THAT THE PRODUCT HAS BEEN USED OR HANDLED OTHER THAN IN ACCORDANCE WITH THE INSTRUCTIONS PROVIDED BY THE MANUFACTURER, INCLUDING BUT NOT LIMITED TO DAMAGE CAUSED BY ACCIDENT, MISHANDLING, IMPROPER INSTALLATION, ABUSE, NEGLIGENCE, OR NORMAL WEAR AND TEAR, OR ANY DEFECT CAUSED BY REPAIR TO THE PRODUCT BY ANYONE OTHER THAN NILES OR AN AUTHORIZED NILES DEALER.

TO OBTAIN WARRANTY SERVICE, TAKE THE UNIT TO THE NEAREST AUTHORIZED NILES DEALER, WHO WILL TEST THE PRODUCT AND IF NECESSARY, FORWARD IT TO NILES FOR SERVICE. IF THERE ARE NO AUTHORIZED NILES DEALERS IN YOUR AREA, YOU MUST WRITE TO NILES AND INCLUDE YOUR NAME, ADDRESS, MODEL AND SERIAL NUMBER OF YOUR UNIT, ALONG WITH A BRIEF DESCRIPTION OF THE PROBLEM. A FACTORY RETURN AUTHORIZATION NUMBER WILL BE SENT TO YOU. DO NOT RETURN ANY UNIT WITHOUT FIRST RECEIVING WRITTEN AUTHORIZATION AND SHIPPING INSTRUCTIONS FROM NILES.

IF THE ABOVE CONDITIONS ARE MET, THE PURCHASER'S SOLE REMEDY SHALL BE TO RETURN THE PRODUCT TO NILES, IN WHICH CASE NILES WILL REPAIR OR REPLACE, AT ITS SOLE OPTION, THE DEFECTIVE PRODUCT WITHOUT CHARGE FOR PARTS OR LABOR. NILES WILL RETURN A UNIT REPAIRED OR REPLACED UNDER WARRANTY BY SHIPPING SAME BY ITS USUAL SHIPPING METHOD FROM THE FACTORY (ONLY) AT ITS EXPENSE WITHIN THE UNITED STATES OF AMERICA. THERE ARE NO OTHER WARRANTIES, INCLUDING WITHOUT LIMITATION, EITHER EXPRESS OR IMPLIED WARRANTIES OF MERCHANTABILITY OR FITNESS FOR A PARTICULAR PURPOSE, WITH RESPECT TO THE PRODUCT.

REPAIR OR REPLACEMENT AS PROVIDED UNDER THIS WARRANTY IS THE EXCLUSIVE REMEDY OF THE CONSUMER/PURCHASER. NILES SHALL NOT BE RESPONSIBLE FOR ANY INCIDENTAL OR CONSEQUENTIAL DAMAGES EXCEPT TO THE EXTENT PROVIDED (OR PROHIBITED) BY APPLICABLE LAW.

SOME STATES DO NOT ALLOW THE EXCLUSION OR LIMITATION OF INCIDENTAL OR CONSEQUENTIAL DAMAGES, SO THE ABOVE LIMITATION MAY NOT APPLY TO YOU. THIS WARRANTY GIVES YOU SPECIFIC LEGAL RIGHTS, AND YOU MAY ALSO HAVE OTHER RIGHTS WHICH VARY FROM STATE TO STATE.

FOR THE NAME OF YOUR NEAREST AUTHORIZED NILES DEALER CONTACT:  
**NILES AUDIO CORPORATION, P.O. BOX 160818, MIAMI, FLORIDA 33116-0818.**



BLENDING HIGH FIDELITY AND ARCHITECTURE®

Niles Audio Corporation  
 12331 S.W. 130 Street Miami, Florida 33186  
 Phone: 305-238-4373 Fax: (305) 238-0185  
[www.nilesaudio.com](http://www.nilesaudio.com)

INSTALLATION GUIDE

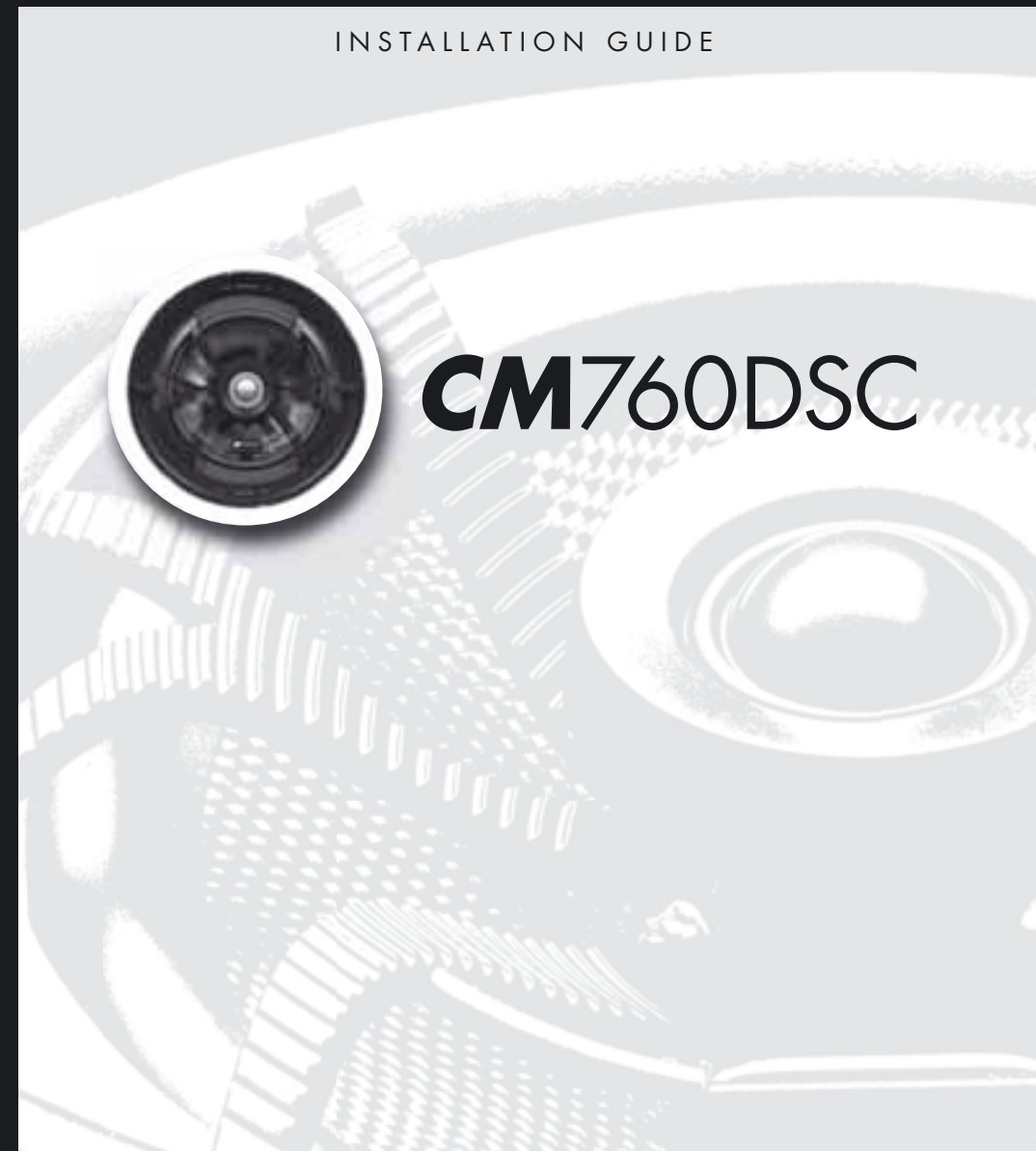

**CM760DSC**

HIGH PERFORMANCE CEILING LOUDSPEAKERS

## CONGRATULATIONS!

Thank you for choosing a CM760DSC loudspeaker from Niles. With proper installation and operation, you will enjoy years of trouble-free use. Niles manufactures the industry's most complete line of custom installation components and accessories for audio/video systems. To see the complete Niles product assortment, visit us on the Internet at: [www.nilesaudio.com](http://www.nilesaudio.com)

## PACKAGE CONTENTS

Each package contains one CM760DSC loudspeaker; 1 Aluminum MicroPerf™ Grille and 1 cardboard paint mask/hole cutout template.

## INSTALLATION CONSIDERATIONS

We recommend using the following tools and material to install your Niles CM loudspeaker:

- Cordless drill with 1/4 – and 1/2-inch drill bits and a 1-inch paddle drill bit (for drilling through studs)
- Keyhole or drywall saw
- Stiff wire, fish tape or glow rods for routing cables
- Phillips screwdriver set
- Rubber gloves and protective eyewear
- Wire stripper
- Stud finder
- Cable ties
- Pencil

Before starting the installation, please observe the following precautions:

- Turn off all system power before making any connections
- Make sure hands are clean before installation
- Always wear protective eyewear when using tools
- Wear gloves when working with fiberglass insulation

## RUNNING WIRES IN WALLS OR CEILINGS

When running loudspeaker wire inside walls or ceilings, use special jacketed cable (a minimum of 18 to 16-gauge two-conductor CL-2 or CL-3 rated loudspeaker wire) to protect the wire and for fire prevention. In some areas, conduit is also required. For a trouble-free installation, low-voltage wire such as loudspeaker wire must be run in accordance with the National Electrical Code and any applicable provisions of the local building code. If you are unsure of the correct installation techniques, wire jacket, or type of conduit to use, consult a professional audio/video installer, building contractor, or the local building and inspection department.

## SELECTING THE LOCATION FOR YOUR LOUSPEAKERS

The CM760DSC center channel loudspeaker is designed to be installed in any standard ceiling. There are two considerations for placing the loudspeaker; ease of running the cable to the loudspeaker and coverage of the loudspeaker. The CM760DSC is best placed as close to the video display as possible, centered as seen from the listening position. Avoid installing the loudspeaker near corners to prevent a “boomy” or diffracted sound. The CM760DSC loudspeaker will cover an area of a circle with a 16-foot diameter when mounted at an 8-foot height and pointed straight down. (See **Figure 1**)

## EXISTING CONSTRUCTION INSTALLATION

**IMPORTANT: BEFORE YOU CUT INTO ANY WALL, REVIEW THE PRIOR SECTION ON LOUSPEAKER PLACEMENT WHEN SELECTING THE LOCATION FOR YOUR LOUSPEAKERS.**

1. When determining the location of the loudspeaker cutout, keep in mind that the mounting dogs will extend 3/4” beyond the cutout. Make sure that you do not place the edge of the cutout directly next to a ceiling joist. Locate the joists using a stud sensor or by hand knocking. Use the supplied cutout template (remove the largest perforated circle and use cardboard square with hole as the template) to determine how large of a hole you will need to cut. These templates are packed with your loudspeakers between the styrofoam packing and the ends of the box.
2. Once you have determined a possible position for the cutout, drill a 1/8” pilot hole just barely through the ceiling (1/2” to 5/8” deep in most homes) in the center of your proposed loudspeaker location.

**BE VERY CAREFUL NOT TO DRILL THROUGH EXISTING WIRES, PIPES, OR STRUCTURE. IF YOU FEEL ANY EXTRA RESISTANCE AS YOU ARE DRILLING, STOP.**

3. Cut a foot-long piece of coat hanger. Bend the wire (creating a right angle) leaving 6” at one end (this allows for the extra width of the mounting dogs). Poke the “L-shaped” wire into the pilot hole and turn it in a complete circle and move it into the ceiling cavity to make sure you have approximately 5-7/8” of depth. If the wire's movement is obstructed by anything, fill the hole(s) with spackle and try another location.

4. If the coat hanger moves freely in a complete circle and you have sufficient depth, hold the template up to the ceiling surface. The cardboard square with the circular hole is the template. The inner perforated circle within the larger circle that was removed in step 1 earlier is the paint mask. Keep it for painting the loudspeaker later. Outline the circular cutout on the ceiling surface lightly with a pencil. Drill the starting point of your cut with a 1/4” bit.

5. If you are cutting drywall use a sheetrock or keyhole saw, cut the hole with the saw at a 45° angle. That way the drywall section can be replaced cleanly if there is an unseen obstruction behind the wall.

**IMPORTANT: BE VERY CAREFUL NOT TO SAW THROUGH EXISTING WIRES, PIPES, OR STRUCTURE.**

**IF YOU FEEL EXTRA RESISTANCE AS YOU ARE CUTTING, STOP.**

## NEW CONSTRUCTION INSTALLATION

### INSULATING THE WALL CAVITY

If feasible, fill the wall cavity with insulation at this point.

### MOUNTING THE NEW CONSTRUCTION BRACKET

The optional CM700DS BKT can be used with the CM760DSC loudspeaker. The hole saving bracket enables a faster and cleaner final installation of the loudspeaker. It forces the drywall installer to cut out the loudspeaker hole for you and provides wire ties for the loudspeaker wire, reducing the risks of accidental loss or movement of the wire. In addition, it enables you to align your loudspeaker with other ceiling fixtures with great accuracy since you can really see exactly where the loudspeaker will be. To install the bracket, first pivot the long wing out until it stops, which will be in straight line with the short wing. The wings and brackets have centering lines to simplify placement of the loudspeaker. Screw one side of the assembled bracket with wings to the joist using one of the supplied screws. Level the bracket. Screw the other side of the bracket/wing assembly to the joist. Two screws on each side make for a very secure installation. Secure the wire to the bracket using bracket's wire tie tab. The drywall installers will cut the drywall to the exact size of the bracket. (See **Figure 2**)

### CONCEALING LOUSPEAKER WIRE FOR A FUTURE INSTALLATION

Attach the loudspeaker wire in a loop between the ceiling joists and carefully mark the exact location of the wire on a set of plans. Ask the general contractor to inform the drywall installers that the loudspeaker wire loops are concealed for future installations.

## UNPACKING AND FINAL INSTALLATION

1. Remove the top piece of styrofoam from the box. You will find one loudspeaker bagged in a lower portion of packing. Remove the loudspeaker from the bag. The metal grille is installed on the loudspeaker and will need to be removed. This is easily done by pulling on the small black fabric strap.
2. Remove the loudspeaker module from the frame by turning the loudspeaker assembly counter-clockwise using the two tabs provided. Place the loudspeaker assembly to the side when removed for installation after the frame has been mounted. Take care to place it so that the woofer, tweeter or crossover on the rear are not damaged. (See **Figure 3**)
3. Insert the frame into the hole by carefully holding it with both hands and angling it slowly into the hole until the frame is flush with the ceiling. Holding it in place carefully with one hand, use a cordless drill to begin mounting the frame.
4. Tighten the four ‘dog’ screws using a #2 Phillips bit. Use low torque and low speed or you may damage the frame. This should pull the frame and mounting dog together (sandwiching the drywall) so that the frame is absolutely flush with the wall surface. There should be no gaps between the wall and the frame.

**IMPORTANT: DO NOT OVER TIGHTEN THE SCREWS! OVER TIGHTENING THEM MAY MAKE THE GRILLE DIFFICULT TO INSTALL**

5. At each loudspeaker location, route the wire through the installed frame, then separate the loudspeaker wire so that at least 2 inches of each conductor are free. Strip away 1/4 inch of insulation from each individual loudspeaker wire.
6. Retrieve the loudspeaker module removed from the frame in step 2.
7. Press down each spring-loaded connector one at a time, insert the appropriate conductor and then release the connector. Check to be sure that the connector is making contact with stripped wire and not the wire jacket. Gently tug on the loudspeaker wire to make sure it is held in place. If not, repeat this procedure until it is.

**IMPORTANT: DO NOT OVER TIGHTEN THE SCREWS! OVER TIGHTENING THEM MAY MAKE THE GRILLE DIFFICULT TO INSTALL**

8. Insert the loudspeaker module into the frame by carefully holding it with both hands and angling it slowly into the frame until the module is seated in the frame. Holding it in place, carefully use the same tabs used to remove it from the frame to turn it clockwise until you feel a ‘click’, which should be approximately an 1/8th of a turn. Take care not to push against the woofer or tweeter as you are inserting the loudspeaker module.

9. Direct the tweeter. The tweeter is directed by gently pressing on the outer edge of the tweeter housing. It will move up to 20 degrees in any direction and can be positioned independent of the woofer assembly. For critical listening, direct the tweeter towards the user's favorite listening position. For surround sound or low volume background listening, create more reflections and thus more ambiance by directing the tweeter towards the sidewalls. (See **Figure 4**)

10. Direct the woofer. The woofer assembly is directed by gently pressing on one or two points of the woofer housing using the edges of the tweeter bridge that are near the blue plastic visible at the outer edge of the woofer. It will move up to 20 degrees in any direction. For critical listening, direct the woofer assembly towards the user's favorite listening position. For surround sound or low volume background listening, create more reflections and thus more ambiance by directing the woofer towards the sidewalls. (See **Figure 5**)

11. Set the Treble level control. Listen to a well-recorded movie or piece of music at the user's favorite listening position. Listen for treble harshness or ringing, particularly when the loudspeakers are placed in a room without carpet. Use the -3dB Treble cut position to correct. Listen for dull or muffled upper frequencies, particularly when the loudspeakers are installed in an area with thick carpet or fabric wall coverings. Use the +3dB Treble boost position to correct. (See **Figure 6**)

12. Set the Dialog level control. Listen to a well-recorded movie featuring mostly dialog at the user's favorite listening position. Listen for thin or less than full voices, particularly when the loudspeaker is placed in the middle of a ceiling. Use the +3dB Dialog boost position to correct. (See **Figure 7**)

13. Install the MicroPerf grille. Start by positioning one edge of the grille slightly inside the loudspeaker. Gently work around the loudspeaker a little at a time until the grille is fully seated. Don't try to insert the grille fully in any one area, as this will make complete installation more difficult. Don't force the grille to fit as you may damage the grille if you apply too much force.

14. Connect the other end of each loudspeaker wire to the receiver (or amplifier) carefully observing polarity.

15. Turn on the home theater receiver and calibrate all loudspeakers in the system according to the receiver manufacturer's instructions.

## PAINTING THE GRILLE AND FRAME

The CM760DSC loudspeaker frame and flush-mount metal grille may be painted without the need for primer. The frame may be painted prior to installation if desired.

1. Install loudspeaker frame into ceiling or wall following the previous steps 1 - 4.

2. Paint the frame of the loudspeaker.

3. Paint the grille separately from the loudspeaker frame. For best results when painting the grille, use a spray gun or airless sprayer. Thin the paint to prevent clogging of the grille holes and apply several light coats instead of one heavy one.

4. Finish installation of the loudspeaker following the previous steps 5-15.

### PAINTING INSTRUCTIONS IF FRAME AND LOUSPEAKER MODULE ARE INSTALLED

1. Remove the smallest perforated circle from the cardboard square template. This is the paint mask that protects the loudspeaker from paint. Gently press it into place inside the baffle.

2. Paint the frame of the loudspeaker.

3. Paint the grille separately from the loudspeaker frame. For best results when painting the grille, use a spray gun or airless sprayer. Thin the paint to prevent clogging of the grille holes and apply several light coats instead of one heavy one. Do not attempt to paint the plastic and cloth grille.

4. Gently remove the paint mask after paint has dried by pressing in the tab in the center and carefully pulling out the mask with your finger. Be very careful not to poke the tweeters with your finger.

5. Finish installation of the loudspeaker following the previous steps 9-15.